

Spec sheet

Invoq | Essence 6-1/1 GN





Simply the essentials

The Invoq Essence gives you all the essential functionalities powered by the latest technology.

Designed to evolve with your needs, it can be upgraded at any time with a range of tailored packages.

Choose your preferred rack system to define capacity and tray sizes. This model accommodates 5–7 trays. With injection steam, smart sensors, and an automated cleaning system, the oven is fast and efficient, while built-in safety features protect both users and operation. Optimal airflow circulation ensures perfect uniformity across every rack.

From installation to daily operation and maintenance, everything has been made simple. With Invoq Essence, you're equipped for today – and ready for tomorrow.

CAPACITY

- 1/1 GN or 400x600 EN
- 2-piece rack
- 7 GN trays with 70 mm runners or
- 6 400x600 EN trays with 80 mm runners or
- 5 trays MultiRack insert with 100 mm runners
- 4.5 kg maximum food load per tray
- 31.5 kg maximum food load per oven

Smart features, simple operation.

Control

Switch effortlessly between convection, combi, and steam modes. The intuitive touchscreen makes navigation simple, giving you precise control at your fingertips for consistent, high-quality results every time.

CareCycle

Choose from three automated cleaning cycles – light, medium, or intense. Designed to be eco-friendly and cost-conscious, CareCycle tablets can be added safely even to a warm oven, and an automatic rinse ensures worry-free operation if interrupted.

Recipes

Use the oven's built-in preset recipes, adjust them to your needs, or create your own from scratch. Master manual mode to maintain full control of quality, while built-in HACCP documentation ensures reliable food safety with downloadable records.

Fit your kitchen

Adapt the Invoq Essence to your layout with left or right-hinged doors, stackable ovens, and flexible hood solutions – condensation or ventless Hoodini. Combine with practical stands to make the perfect fit for any kitchen.

Electricity

Dimensions & weight



Dimensions excl. handle (HxWxD) [mm]	851 x 937 x 826
Dimensions incl. handle (HxWxD) [mm]	851 x 937 x 908
Dimensions incl. handle and stand (HxWxD) [mm]	1550 x 937 x 908
Shipping dimensions (HxWxD) [mm]	950 x 1000 x 1200
Net weight [kg]	127
Shipping weight [kg]	147
Clearance (left, back, right) [mm]	0 x 0 x 40
Maximum working height [mm] basic stand	1355

Power requirements



Power consumption [kW]	10.3
Convection output [kW]	9
Grid supply frequency [Hz]	50/60*
Voltage 220-240 V 3P AC	
Pre-fuse [A]	32
RCD model	B/F
Voltage 400 V 3PN AC	
Pre-fuse [A]	16
RCD model	B/F
Voltage 415 V 3PN AC	
Pre-fuse [A]	16
RCD model	B/F
Voltage 440 V 3P AC	
Pre-fuse [A]	16
RCD model	B/F

Water requirements



Water connection [inches]	3/4
Drain [mm]	Ø50
Water pressure (min-max) [bar]	1-6
Water flow [l/m]	5.5

IP classification



IPX5

IP class	IPX5
----------	------

Data



Wi-Fi module (option)	IEEE 802.11 b/g/n (2.4 GHz)
LAN	RJ45

*The oven is built from factory for either 50 Hz or 60 Hz grid supply, except 220-240 V 3P which comes only with 50 Hz. Further technical information can be found in the installation manual.

- A Drain outlet
- B Air outlet (drain)
- C Air intake
- F Ethernet connection
- G Electrical connection
- W Water inlet (HydroShield water filter or reverse osmosis)
- X Water inlet

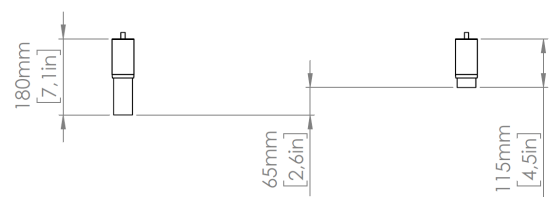
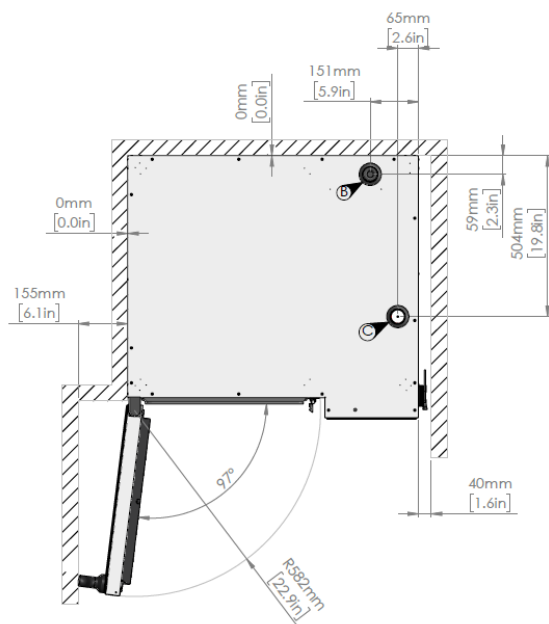
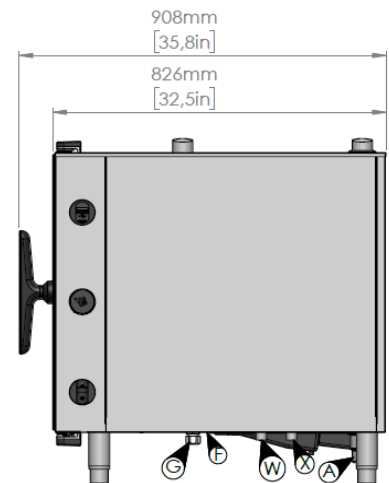
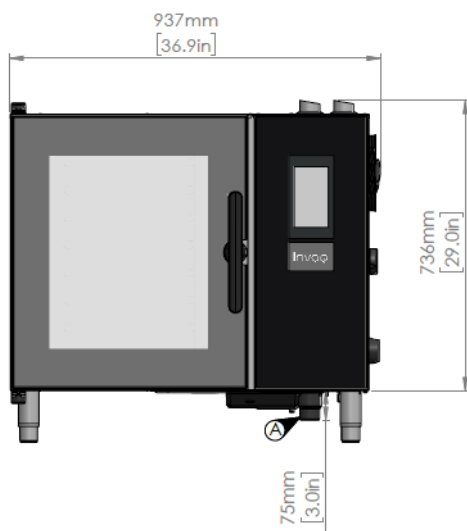

Features

Intelligence

CareCycle	Fully automatic, recirculating tablet-based cleaning system. System guidance to appropriate cleaning program and required amount of detergent. Automatic rinse after interrupted cleaning cycle.
CookTimeCorrection (CTC) / BakeTimeCorrection (BCT)	Intelligent sensors detecting unexpected changes in temperature and compensating accordingly.
Humidity control, CombiSpeed	Level-controlled humidity injection for improving low-temperature cooking optimising tenderisation and yield of larger products. 10 different humidity levels.
Power failure	Automatic restart after power failure allowed up to 30 minutes to ensure finalisation of running programs. Automatic rinse after interrupted cleaning process for safe cooking. User notification of failure occurred and documents via HACCP.

Operation

Convection, temperature range	30-300°C / 85°-572°F 300°C / 572°F possible for 15 minutes, then reducing to 250°C / 480°F for continued run in manual mode.
Steam, temperature range	30-130°C / 85°-265°F Injection steam for rapid and pure steam for optimal performance even at low temperatures below 100°C / 212°F.
CombiSpeed, temperature range	30-250°C / 85-480°F CombiSpeed: Power steam adjustable in 10 levels for reduced cooking time and tenderizing products.
Cool down	Rapid cool down function with possibility for doing it with the door open or by use of water.
Proving	Humidity regulated proving function for optimum proving of baked products
InjectionSteam	In steaming mode, steam is generated by injecting water directly on to the heating elements and circulating it with the fan creating fast and efficient steam.
Steam on demand	Push and hold in manual mode or push and select between 1-30 seconds.
Steam on demand in recipes	Programmable steam on demand between 1-30 seconds. Pause can be added between steps for optimal crust.
Recipes	The oven can hold 500 recipes. Each recipe can hold up to 10 different steps. A set of preset recipes are installed on the oven from factory. Recipes can be grouped, e.g. bakery products, Italian cuisine. Choose from icons or photos, available from a preinstalled library, or upload own images. Simple upload or transfer between Invoq ovens via USB.

Safety

Fan wheel brake	Rapid fan stop.
Overheat protection	Overheating protection for convection heat.
Contact temperature	Maximum contact temperature of oven door 70°C.
3-pane glass door	Swivelling glass panes with built-in ventilation and energy-optimised coating.
Tablet cleaner and descaler	Tablet-based environmentally conscious cleaner and descaling chemicals for improved work safety.
HACCP	HACCP files are automatically stored for 180 days and can be downloaded in PDF format to ensure food safety documentation. Stored on the oven when not connected. HACCP data includes production time, production duration, preparation temperature and core temperature.
Maximum rack height	Maximum working height of 1.6 m.
Display lock	Ensuring no interruption with operation when cleaning the surface.
IP protection	Protection class IPX5 protecting against water jets from all directions.
Door handle	Two-step safety handle as standard.
Cavity	DIN 1.4301 steel with seamless welding and rounded corners for optimal airflow and cleaning.

Network

USB	Integrated USB interface for software, recipe and HACCP handling.
LAN	Ethernet interface for wired connectivity to Open Kitchen.

Care

CareCycle	Fully automatic, recirculating tablet-based cleaning system with 3 cycles, Light, Medium and Intense. Non-pressure-dependent system. System guidance to appropriate cleaning program and required amount of detergent. Automatic rinse after interrupted cleaning cycle ensuring no chemical residue left in the chamber.
CareCycle Clean tablets	Phosphate-free formula of the detergent for an eco-conscious choice
CareCycle Descaler tablets	Descaling of cavity for proper cleaning of hard water deposits.
HydroShield	Use carbon filtered water removing lime and gypsum.
3-pane glass door	Swivelling glass panes for easy cleaning.
External	Easy external clean due to stainless steel and glass surfaces and IPX5 protection.

Comfort

Time format	Adjustable in 24-hour format or am/pm.
Timer start	Customisable automatic timer starts. Allowing the oven to start and/or preheat unsupervised.
Timer modes	HH:MM - MM:SS - continuous time
Display	Digital temperature display adjustable in °C or °F, display of target and actual values.
Fan speed	1 or 2 fan wheels. Reversible fan ensuring uniform results. Optimum distribution of air and steam in oven chamber. Adjustable fan with 5 steps; low fan speed - ideal for light/delicate products The fan can be set manually in convection, steaming and fan mode.
Lighting	LED lighting from the door with high illumination of cooking chamber. Energy saving and long life.
Touch display	Fast reacting and intuitive touch display for smooth and easy operation.
User interface	Capacitive 7" TFT colour touch screen with super wide view for optimal viewing angles. Simple and intuitive operation by self explanatory symbols and guidance eases the operation like a smartphone, operated by Android 9. Compatible with Middleby UI for multi devices with same control.
Languages	27 languages preset for operation and trouble shooting.
Cooking methods	3 operating modes and/or 4 cooking modes.
Supervision access	View or change the operating mode.
Customisation	Customise the home screen to allow easier access to favourites, cleaning and MenuPlanner removing the risk of operator errors. Customise notes with alarms to guide staff. Incorporate guidelines to recipes for optimal usage and elimination of errors.

Installation, maintenance & environment

Start widget	Correct and stress-free installation incl. location (sea level) customisation.
Service widget	Correct and easy maintenance incl service diagnosis and self-test functionality.
Fitting	Left- or right-hinged door for optimal ergonomics and kitchen design.
Service access	Easy service access from one side of the oven only.
Water filtration	HydroShield water treatment is recommended for optimal operation. User notification by oven for replacement.
Warranty	Standard warranty or extended according to purchase agreement with distributor.
Maintenance	Regular maintenance is recommended according to the manufacturer's guideline by trained service partners.
Ambient temperature	Maximum 50°C ambient operation temperature.

Upgrade options

Intelligence

CareCycle	Upgrade CareCycle with 2 Eco modes. Turbo Cleaning in just 15 minutes. Organiser for scheduling cleaning on weekly basis
MenuPlanner	Up to 10 integrated timers for notifications. Software to input and group recipes with drag and drop functionality. Automatic alert to request staggering of loading when grouping up to three specific recipes.
SmartChef	Intelligent cooking automation selecting the optimal cooking settings. 3 step simple settings for optimal cooking results.
Humidity control, CombiSense	Percentage-based automatic humidity system for high-temperature cooking maintaining natural moisture, flavour and colour of the product. Sensors supervise and control the Maillard reaction for accurate results.
QSR	QSR, Quick Select Recipes, is a tailored smart user interface allowing recipes as favourites on the home screen. 9 thumbnail recipes per page - up to 9 pages for a total of 81 recipes. Option of locked down user interface to prevent manual operation.
Connectivity, Open Kitchen	Cloud solution for menu management, recipe distribution, preventive maintenance, real-time overview of fleet, food safety documentation and consumption data overview.

Operation

CombiSense, temperature range	30-250°C / 85°-480°F Accurate automatic humidity adjustment.
Temperature probe	External multipoint core temperature probe with accurate sensors. Always at ambient temperature. for easy use. Less exposed to wear and tear. Including normal operation, DeltaT and Cook& Hold.
Delta-T	Cooking method based on the product's core temperature for gentle preparation tenderising meat and reducing shrinkage.
Cook & Hold	Cooking method using Delta-T as cooking mode until just before the desired temperature is reached after which the temperature is maintained, while automatic humidity control ensures the optimal conditions with a high moisture level and minimum shrinkage.

Network

Wi-Fi	WLAN upgrade for wireless connectivity to Open Kitchen.
Connectivity	Open Kitchen cloud-based system enabling management of oven fleet and general facility management.

Comfort

Fan speed	When SmartChef or MenuPlanner is added, 9 fan speeds becomes available - also in manual and recipe operation.
Cooking methods	Up to 7 operating modes and/or 5 cooking modes. When adding features like SmartChef, MenuPlanner, QSR, CombiSense

Care

Hand shower	Hand shower can be an add-on to be located on the side, with separate closing mechanism. The external hand shower is designed with focus on ergonomics and work environment.
Connectivity	Monitoring and consumption overview via the Open Kitchen cloud solution. Allowing for remote service diagnosis.

Unlock more with Essence

Tailor your Invoq Essence with upgrade packages that add intelligence, connectivity, and convenience as your business grows. Each package includes the necessary hardware and software, unless otherwise stated.

Invoq Essence Upgrade Packages

Precision Cooking Package	Adds a multipoint core probe with Delta-T and Cook & Hold functions. Use the probe also with RackTimer for precise monitoring and consistent results.	HW + SW
Climate Package	Introduces a humidity sensor unlocking CombiSense, ClimateControl, and intelligent steaming for improved energy efficiency and cooking quality.	HW + SW
Intelligence Package	Combining the Precision and the Climate packages and further unlock SmartChef/SmartBaker automation, MenuPlanner, and nine adjustable fan speeds for ultimate flexibility.	HW + SW
QSR Package	Activates Quick Select Recipes mode with a locked screen and customized user interface for streamlined quick-service operations.	SW
Care Package	Enhances CareCycle with two eco modes, a turbo cleaning cycle, and a cleaning organizer for smarter, faster, and more sustainable maintenance.	SW
Open Kitchen Package	Enables LAN connectivity with an Open Kitchen license for remote monitoring, recipe distribution, and data-driven management.	HW + SW
Wi-Fi Package	Adds a Wi-Fi module with one year of Open Kitchen subscription and access to automatic software updates.	HW + SW
Handshower Package	Adds an ergonomic external handshower with a separate closing mechanism for flexible and easy cleaning.	HW

Options

Right-hinged door

Condensation hood (electric oven)

Condensation hood Stackit (electric oven)

Hoodini ventless hood (electric oven)

Note: Hoodini requires Climate package for Invoq Essence.

Hoodini ventless hood Stackit (electric oven)

Note: Hoodini requires Climate package for Invoq Essence.

Stackit (electric oven)

Special voltage (upon request)

Wi-Fi module

Open Kitchen cloud solution

Racks

6-1/1 GN 70mm 7 trays U-shaped

6-1/1 GN 85mm 6 trays U-shaped

6-1/1 GN MultiRack 100mm 5 trays (1/1 GN - 400x600 - US sheet)

6 - 400x600 EN - 80mm 6 trays L-shaped

CareCycle

CareCycle Clean tablets

CareCycle Descale tablets

HydroShield L 3600 Complete

HydroShield XL 6000 Complete

HydroShield L 3600 Replacement filter

HydroShield XL 6000 Replacement filter

Stands

Basic stand

Stand for table & Stackit

Options for stand (add-on):

Racks 1/1 GN (up to two)

Racks 400x600 EN (1 pc)

Castors (set of four)

Bracket for filter

Exterior cabinet & doors

Accessories

Cable and plug 6-1/1GN, 5G2,5mm², 16A CEE Plug (only available with 3PN)

Installation kit

Heat shield

USB key

GET IN TOUCH.

As your oven specialist,
we always do our
utmost to help our
customers. Worldwide.

HOUNÖ A/S
Alsvej 1
DK-8940 Randers SV
Denmark

T: +45 8711 4711
M: houno@houno.com

www.houno.com

Part of

