



Catalogue
FOOD SERVICE

Induction

Chapter
DISHWASHING
Specific Model
WHP-503 SN D 400V3N50Hz

Zone:
Item: 2

19110565

14/04/2026

DENOMINATION:

Hood type dishwasher sanitary for 500x500 basket with rinse pump, detergent dispenser and double skin.

DESCRIPTION :

INTERFACE

- 2.8" backlit colour (TFT) liquid crystal display.
 - Colour-coded status indicators.
 - Display of operating parameters, such as tank and boiler temperature or cycle time.
 - Indicators of tank and boiler heater operation.
 - Self-diagnosis and error signalling.
 - Timer function to be able to schedule the machine to switch on or off at a specific time.
 - Power-saving mode (stand-by): Reduction of power consumption when the machine is not in operation.
 - User-selectable programmes according to equipment use (glass, crockery and bar) and machine-specific programmes.
 - Technical menu (via password):
 - View of all the inputs of the electronics and act on the outputs to facilitate the quick detection of problems.
 - Modification of operating parameters, such as heating temperatures, washing and rinsing times, etc.
- Membrane keypad with 5 buttons.

PROGRAMMES:

- Light: 60s (2,1 l/cycle, Wash T^a: 60°C, Rinse T^a: 85°C)
- Standard: 90s (2,3 l/cycle, Wash T^a: 60°C, Rinse T^a: 85°C)
- Sanitary programmes according to UNE-EN ISO 15883-1/3:
- A0=30: automatic duration (2,3 l/cycle, Wash T^a: 74°C, Rinse T^a: 85°C)
- A0=60: automatic duration (2,9 l/cycle, Wash T^a: 74°C, Rinse T^a: 85°C)

CONSTRUCTION DETAILS

- Double-skin hood with thermo-acoustic insulation and metal runners to reduce lifting effort and noise level.
- Fully stamped tank with no welds or sharp edges. The washing chamber is free of interior pipes, edges and holes where dirt can accumulate.
- Easy cleaning of internal parts without the need to remove the rack support. The support can be tilted upwards by 90°.
- The machine and its tables can be installed in a straight line or in a corner. In addition, it is possible to change the working direction left-right or right-left.
- Upper and lower wash and rinse arms.
- Magnetic micro switch to stop the cycle in case of accidental opening of the hood.
- Cycle start activated by hood down or manual (deactivated).
- Easy handling thanks to the surrounding handle on the hood.
- Double in stages filtering system:
- Polypropylene pump suction filter that blocks the lightest dirt, protecting the washing pump.

DIMENSIONS



X Width	630 mm	X Gross width	765 mm
Y Depth	750 mm	Y Gross depth	905 mm
Z Height	1480 mm	Z Gross height	1610 mm
Net Weight	108,0 kg	Gross Weight	119,0 kg
Net Volume	0,700 M3	Gross Volume	1,120 M3

ELECTRICITY TECHNICAL SPECIFICATIONS

Electric power	14,250 KW
Voltage	380-415V - 3N
Phases	3N
Electric frequency	50Hz
Amperage (A)	22.83
Engine power	0,750 KW
Heating power	13,500 KW

MULTIPOWER

Connection	Rated power (kW)	Rated Current (A)	Boiler (kW)	Tank (kW)	
400V, 3N~	14,25 kW	22,83 A	9 kW	4,5 kW	SIM
230V, 3~	14,25 kW	37,15 A	9 kW	4,5 kW	SIM

WATER TECHNICAL SPECIFICATIONS

Pressure	H2O: 100-400kPa (1-4bar)
----------	--------------------------

CONNECTIONS TECHNICAL SPECIFICATIONS

Drain 1 diameter	25MM
Cold softened water 1 diamete	3/4

TECHNICAL FEATURES

Boiler capacity	10,000 L
Rinsing pump power	0,130 KW
Boiler capacity	10,000 L



Catalogue
FOOD SERVICE

Induction

Chapter
DISHWASHING
Specific Model
WHP-503 SN D 400V3N50Hz

Zone:

Item: 2

19110565

14/04/2026

- Stainless steel tank surface filter, retains coarse dirt. The filter can be easily removed without disassembling the wash and rinse arms.
- Insulation in boiler.
- Dual-flow wash pumps: one input and two outputs, one for each arm, without the need to split the flow to avoid power loss and reduce noise.
- Soft-start: The cycle starts slowly and gradually increases to maximum speed to prevent light items such as glassware and crockery from falling out.
- Wash/rinse arms. Duo-KLIP:
 - A combined wash and rinse arm at the same level, made in stainless steel as option (X), preventing the two arms from getting in each others way.
 - Low friction and very light arm that allows all the power supplied by the pump to be used for washing dishes and not for rotating the arm.
 - Washing and rinsing orifices designed with specific geometry to reach the most inaccessible places. They spray water precisely, achieving 10% lower water consumption, reducing electricity and chemical consumption and therefore helping to minimize operating costs.
 - The clip-on snap-on coupling makes it easy to assemble and disassemble for cleaning.
- Rinse pump:
 - Rinse even at low mains pressure (1 bar). Water is drawn from the boiler through a booster pump and sent to the rinse nozzles of the machine ensuring optimum and constant pressure. This system, being independent of mains pressure, thanks to the presence of the "Air Break", leads to lower water consumption and therefore lower energy consumption.
 - The temperature of the water in the boiler is constant throughout the rinse, as this water has not been mixed with cold mains water during the refilling phase.
 - The "Air Break" system prevents backflow into the water supply system of non-potable water contaminated with rinse products, detergents and food waste. Type A nonreturn device in compliance with EN 1717.
 - Accurate rinse aid dosing with a constant water flow.
- Thermostop: Starts the rinse when the rinse temperature required for a hygienic wash result and correct drying of the dishes has been reached. The rinse cycle will be extended to a maximum time of ten minutes if the rinse temperature setpoint is not reached.
- Thermostatic filling: Speeds up the machine set-up time as the tank is filled with water previously heated in the boiler, which is more powerful. Only available for models with rinse pump.
- Peristaltic rinse aid dosing as standard.
- Peristaltic detergent dispenser included (D).
- Gravity drainage.

STANDARD OPTIONS :

- Detergent dispenser
- Double skin





Catalogue
FOOD SERVICE

Induction

Chapter
DISHWASHING
Specific Model
WHP-503 SN D 400V3N50Hz

Zone:

Item: 2

19110565

14/04/2026

- Stainless steel surface filter
- Stainless steel wash and rinse arms

SUPPLIED ACCESSORIES:

- 19000484 Glass basket, 500x500x110 mm. 1ud.
- 19000487 Basket for 16-18 plates, 500x500x110 mm. 1ud.
- 19000792 Cutlery basket for 15 pieces of cutlery, 105x105x130 mm. 1ud.



Catalogue
FOOD SERVICE

Induction

Chapter
DISHWASHING

Zone:

Specific Model
WHP-503 SN D 400V3N50Hz

Item: 2

19110565

14/04/2026

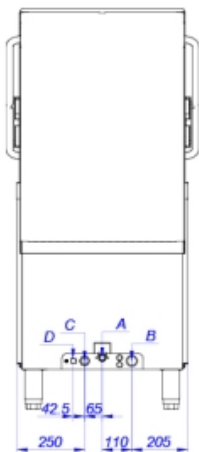
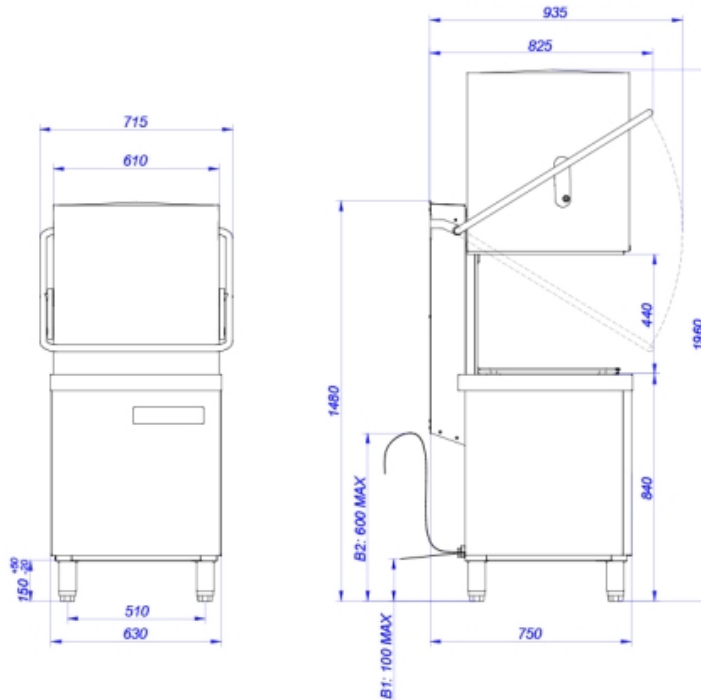

A: ENTRADA DE AGUA 3/4"
B1: DESAGÜE Ø25 L= 1500mm
B2: DESAGÜE CON BOMBA Ø17 L= 3000mm
C: ALIMENTACIÓN ELECTRICA
D: ETHERNET

A: WATER INLET 3/4"
B1: DRAIN Ø25 L= 1500mm
B2: DRAINAGE PUMP Ø17 L= 3000mm
C: ELECTRICAL CONNECTION
D: ETHERNET

A: ARRIVÉE D'EAU 3/4"
B1: VIDANGE Ø25 L= 1500mm
B2: POMPE À VIDANGE Ø17 L= 3000mm
C: CONNEXION ÉLECTRIQUE
D: ETHERNET

